

SUPPLY END

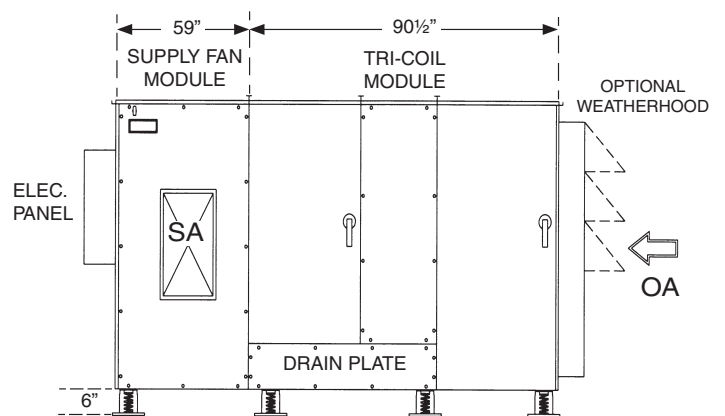

SUPPLY SIDE

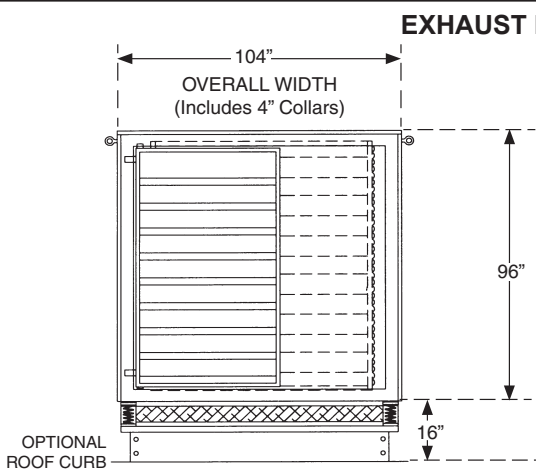

EXHAUST END

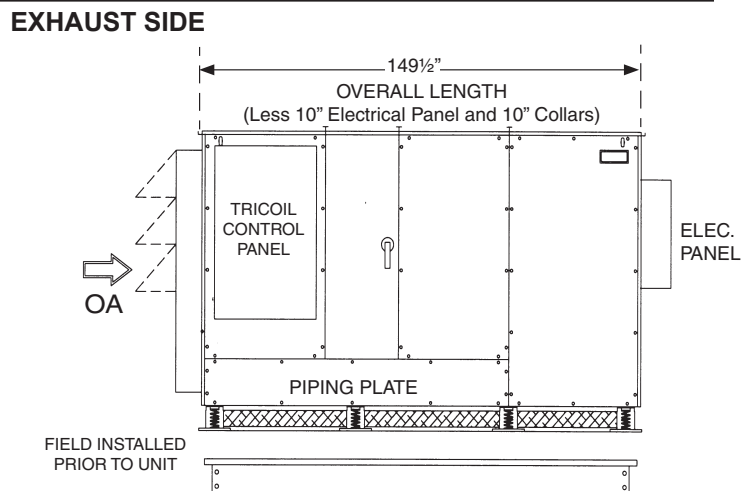

EXHAUST SIDE

# 8815-TRO

14,000 to 16,000 CFM

May, 2003

## SUPPLY FAN PERFORMANCE AND MOTOR SELECTION GUIDE

(Intersect CFM with external static pressure to determine fan h.p.)

CFM	OUTLET VEL. FPM		0.5 ESP	1.0 ESP	1.5 ESP	2.0 ESP	2.5 ESP	3.0 ESP	3.5 ESP
14000	2236	RPM BHP hp	965 9.57 15	1008 10.77 15	1051 12.05 15	1093 13.38 15	1133 14.72 20	N/A	N/A
14500	2316	RPM BHP hp	990 10.35 15	1032 11.6 15	1074 12.92 15	1114 14.24 20	N/A	N/A	N/A
15000	2396	RPM BHP hp	1018 11.27 15	1059 12.56 15	1099 13.89 20	1139 15.24 20	N/A	N/A	N/A
15500	2476	RPM BHP hp	1048 12.31 15	1088 13.65 20	1127 15.01 20	N/A	N/A	N/A	N/A
16000	2556	RPM BHP hp	1086 13.68 20	1125 15.08 20	N/A	N/A	N/A	N/A	NA

FAN MOTOR AMP DRAW CHART			
hp	208	240	480
15	41.0	38.0	19.0
20	54.0	50.0	24.9

ACCESSORIES AMP DRAW CHART			
	208	240	480
Damper Motor (ea.)	0.75	0.75	0.50
TRICOIL Pump Motor	6.00	6.00	6.00
Hot Water Modulating Ball-Valve	0.20	0.20	0.10
Temperature Sensor (ea.)	0.50	0.50	0.25
Lights and Receptical	12.00	12.00	6.00
Variable Frequency Drive for Fan (ea.)	0.50	0.50	0.25
Variable Frequency Drive for TRICOIL	0.25	0.25	0.15

Performance numbers are based on optimum conditions. Consult factory for precise performance.

**Berner Energy Recovery Incorporated**

111 Progress Avenue, New Castle, PA 16101 / Telephone (724) 657-5301 / FAX (724) 652-0682 / [www.bernerenergy.com](http://www.bernerenergy.com) / [info@bernerenergy.com](mailto:info@bernerenergy.com)

©Copyright, 2003 Berner Energy Recovery, Inc.