

VSB

POSITIVE INDIRECT GAS ONE HEATER SYSTEM

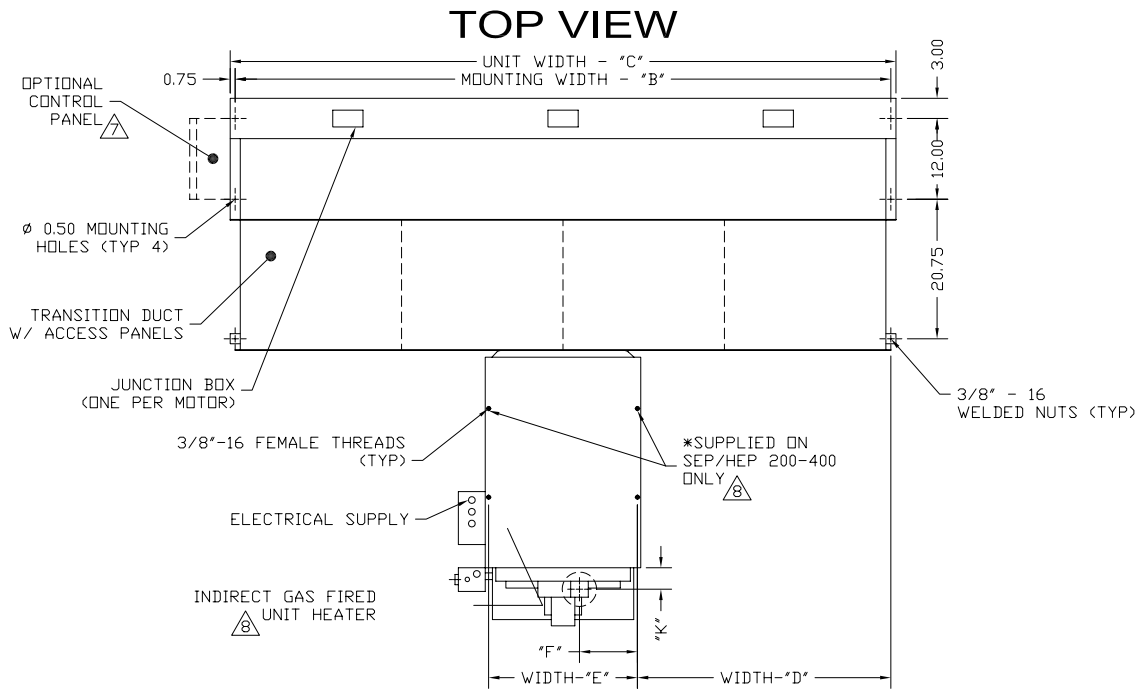

NOTES:

- 1 AIR CURTAIN MUST BE INSTALLED SO AIR STREAM IS NOT OBSTRUCTED WHEN DEFLECTED 20° TO EITHER SIDE OF ϕ .
- 2 ELECTRICAL CONNECTIONS TO BE FLEXIBLE.
- 3 FIELD VERIFY DIMENSIONS.
- 4 ANCHORS TO SUPPORTING STRUCTURE BY OTHERS.
- 5 ADEQUACY OF SUPPORTING STRUCTURE IS TO BE VERIFIED BY A PROFESSIONAL STRUCTURAL ENGINEER.
- 6 SUPPLY PRESSURES HIGHER THAN 0.50 POUND REQUIRE INSTALLATION OF AN ADDITIONAL SERVICE REGULATOR EXTERNAL TO THE UNIT.
- 7 OPTIONAL CONTROL PANEL AVAILABLE: LEFT HAND MOUNT, RIGHT HAND MOUNT, & REMOTE. PLEASE SPECIFY.
- 8 SEP 200-400 FURNACES HAVE TWO FANS AND FOUR MOUNTING POINTS.
- 9 DIMENSIONS IN INCHES.

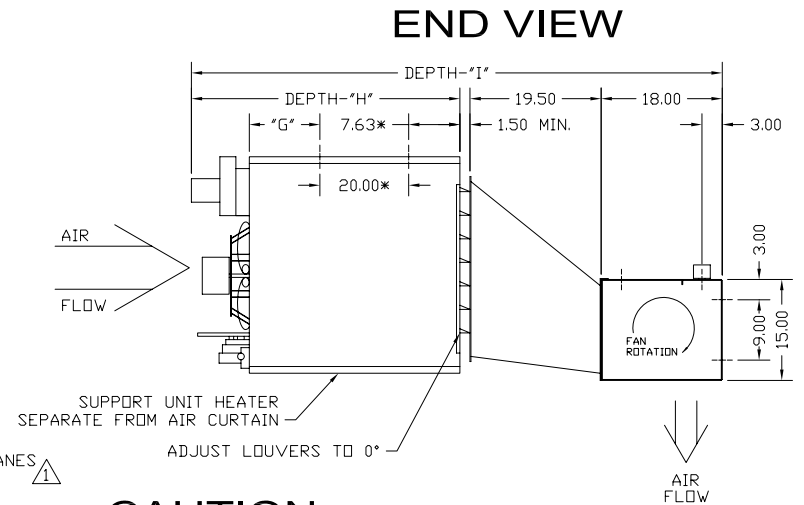
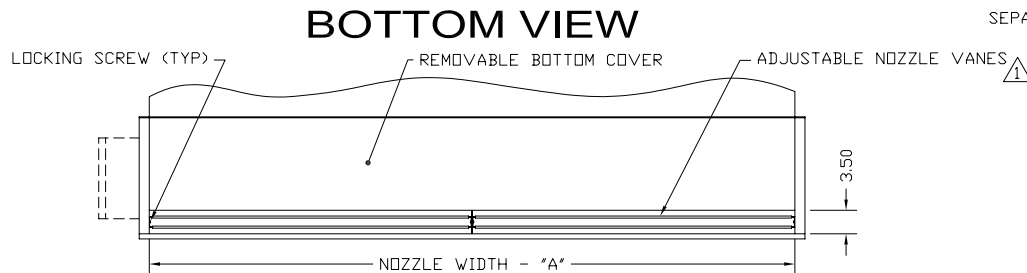
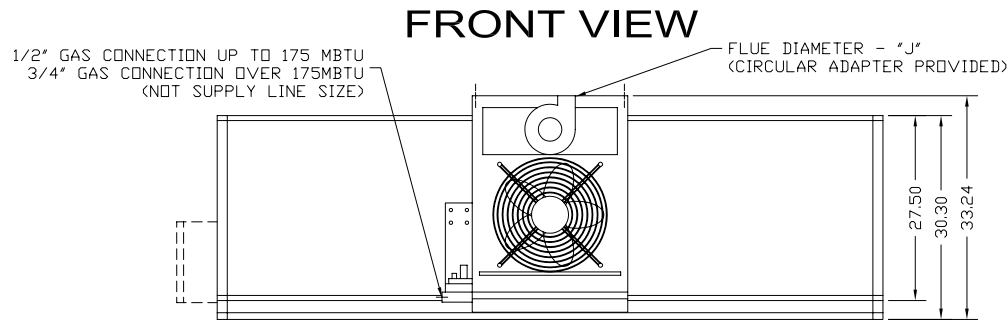

CAUTION:

HEATER IS EQUIPPED FOR A MAXIMUM GAS SUPPLY PRESSURE OF 1/2 POUND, 8 OUNCES, OR 14 INCHES WATER COLUMN.

FOR DIMENSIONS SEE DWG. #VSBV0014

PROJECT		
LOCATION		
ARCHITECT		
ENGINEER		
DWG. NO.	VSBV0013	TITLE: BERNER
DATE	13APR07	MODEL VSB AIR CURTAIN
BY	D. Johnson	INDIRECT GAS FIRED - ONE HEATER SYSTEM
REPLACES	-	
BY	-	BERNER INTERNATIONAL CORP. NEW CASTLE, PA.